

EXTENDING the Operation of a Position-Sensitive Photomultiplier Tube to 1 Million
Counts Per Seconds

A. Fallu-Labruyere ^{a,*}, H. Tan ^a, W. Hennig ^a, Y.X. Chu^a, M. Momayezi^b, W.K.
Warburton ^a

^a XIA, LLC, 8450 Central Avenue, Newark, CA 94560, USA

^b Bridgeport Instruments, Oakland CA, USA

Abstract -- While position sensitive photomultiplier tubes (PSPMTs), coupled to fast scintillators, are widely used as photon detectors in applications such as medical imaging systems (PET, gamma camera, etc.) where it is desirable to combine good time resolution with the capability of locating the point of photon interaction, their count rate limitations (of order of tens of thousands of cps) have precluded their use in more demanding applications. Recently, in a neutron imaging application, we found that, by using custom designed fast anode and dynode readout circuits, coupled to a fast digital pulse processing board, we could operate a PSPMT at rates approaching 1 million cps while retaining good position resolution, linearity and time resolution. These developments therefore significantly extend the range of PSPMT application.

Keywords: PSPMT, Nuclear Imaging; Digital Signal Processing; Digital Spectroscopy

PACS: 07.50.Qx; 07.85.Nc; 84.30.Sk

* Corresponding Author. Tel.: + 1 510 494 9020 ext. 15; fax: + 1 510 494 9040; e-mail: anthony@xia.com (A. Fallu-Labruyere).

1. Introduction

A PSPMT consists of a photocathode sensitive to the scintillation light wavelength, multiple dynodes for photo-electron multiplication, and a pair of crossed multi-wire anodes. Typical anode readout uses an interconnected chain of resistors, both ends of each chain being terminated by a resistor that converts the collected photocurrent into voltage. For each photon interaction event within the scintillator, the ratio of the difference between a pair of anode end voltages to their sum provides an interpolated position measurement along one axis and hence a projection of the event's location on the photocathode. For each event, time of interaction is provided by the last dynode. In this work these interpolation computations were performed in real time for each interaction using an XIA Pixie-4 gamma ray spectrometer.

2. Objectives.

The main objectives were to implement a fast readout circuit capable of providing position and time information to potentially increase the detector throughput and reduce exposure times.

3. Implementation

3.1 Anode readout.

We designed and implemented fast anode and timing circuits, and tested them on Hamamatsu PSPMT 3" R2486 and 5" R3292. As delivered, the anode wires are interconnected with 1k Ω resistor. This resistance coupled with the cable and wires stray capacitance shaped the anode signal with rise times and decay times respectively of about

200ns and 420ns (Fig. 1). Sustaining high event throughput efficiency would require some effort in the signal processing implementation to disentangle overlapping events at high speed.

Instead, we chose to lower the anode interconnection resistance to 10Ω to collect the photocurrent two orders of magnitude faster, such that a simple signal integration to recover pulse energies will both be simpler to implement in Field Programmable Gate Arrays (FPGA) and require low processing time (dead time). The measured signal is presented in Fig.2.

Since the XIA Pixie-4 spectrometer, which digitizes pulses at 75MHz was used to instrument the devices, a minimum of 8 sample points on the pulse were required to prevent digitization errors. We then used a 4 pole Gaussian filter, each pole located at 23MHz to slow down the photocurrent pulse and increase the number of pulse sample points and measure the pulse height to acceptable accuracy

3.2 Timing circuit

The timing information was extracted using the circuit is presented in Fig. 3. The bias circuitry was partially represented. The “Timing Signal” was filtered and digitized like the anode signals. The signal shape is presented in Fig.4.

4. Results and discussions

4.1 X-Y mapping function and position resolution.

The PSPMT was gain calibrated by fitting the single photo-electron peak (SPP) obtained when the anode signals were ganged, and was then set to 10^5 . We stepped a fast green LED across the PSPMT surface every 5mm using a computer-controlled X-Y table; position resolution was evaluated when the LED was shining the photocathode surface

through a pin hole ($\sim 125\mu\text{m}$ in diameter). The anodes and dynode signals were read out by two XIA Pixie-4 spectrometers [1]. Triggered traces were acquired and analyzed offline for position and timing. The computed image is reported in Fig. 5.

The data were acquired using a repetitive pulser clocked at different frequencies, with the LED centered on the PSPMT surface. Fig. 6 reports the position resolution as a function of rate and number of incident photoelectrons. The curve “Ref. 1” refers to the position resolution quoted by the device datasheet [2]. The differences can be first explained by the calibration method, and the limited precision to which the SPP was measured. Second, our readout circuit is more sensitive to signal noise than the original readout circuit with larger trans-impedance, which can explain the degradation of the position resolution at low number of photons.

4.2 Time resolution

We measured an intrinsic Pixie-4 time resolution of 250ps, which did not limit the measurements below. Time resolution was evaluated using the positron emission of Na-22. Signals from the two detectors were fed into two Pixie-4 channels. The faster detector was used to trigger the acquisition of both pulses. A constant fraction algorithm was applied to compute time of arrivals.

Table 1 reports examples of time resolution measured with scintillators of different speed. At the time of the experiment, we did not have any LSO or BGO crystals to make an extended comparison. We only compared (last line) the performance of the timing signal with a linear focused (LF) PMT, and demonstrated that the designed PSPMT timing signal and LF PMT timing signal (anode) have comparable timing performance.

Better time resolution could have been obtained by using a LF PMT optimized for timing.

Finally, we measured that the absolute time of arrival of photoelectrons on the anode does depend on the photocathode interaction location, and variations of up to 5ns can be observed on both devices (R2486, R3292). These data are plotted in Fig. 7. Since the time of arrival variations is comparable to the time resolution measured, a careful calibration of time with position has to be made to measure time accurately across the entire photocathode.

4.3 Throughput capability.

All the results presented were made in listmode run type, where the triggered traces were digitized and processed offline. Assuming a 300ns dead time for one pulse to be free from any remaining energy from previous pulse and dead time free pipelined and buffered signal processing, the RC readout coupled to this FPGA and DSP based architecture [1] has the potential of reaching a maximum output count rates of 1.2 million cps at 3.3 million input cps.

5. Conclusions

A PSPMT fast anode read out circuit with fast time reference signal was implemented and characterized. The anode circuit provided comparable position resolution performance as usual cross wire readout reported by the datasheets [2] and sustained its position resolution with measured rates of half a million cps. To achieve time resolution in the nano-second range, it is essential to calibrate photoelectron time of flight with respect to position.

The capability to instrument fast scintillators at higher throughput increases the system detection efficiency and extends the scope of operation of such devices for x-ray (PET, SPECT), gamma-ray and neutron imaging applications.

References:

[1] Pixie-4 spectrometer datasheet, www.xia.com/DGF_pixie-4.html

[2] R2486 PSPMT datasheet http://usa.hamamatsu.com/assets/pdf/parts_R/R2486.pdf

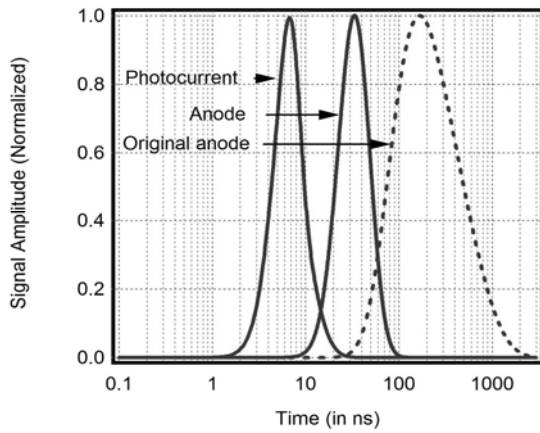

Fig. 1: Simulated anode signal shapes.

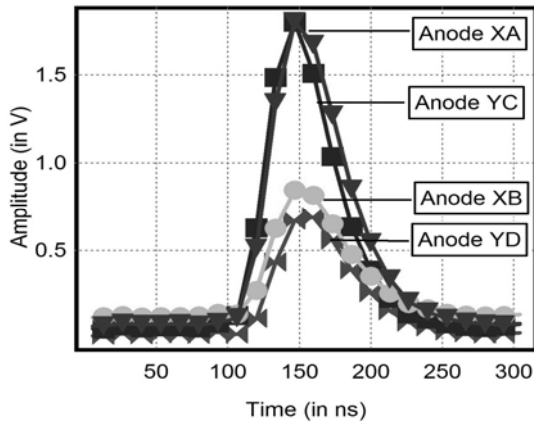

Fig. 2: Measured anode signal pulses (R2486)

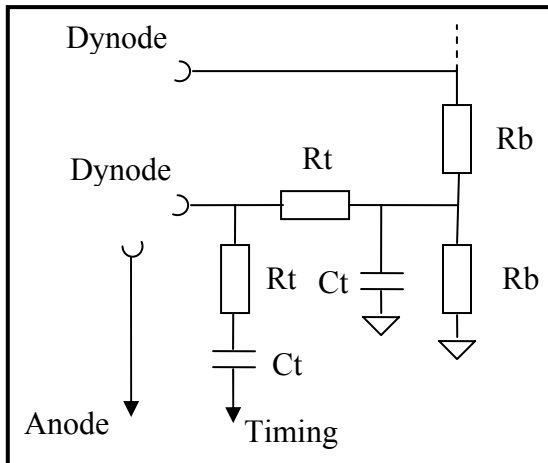

Fig. 3: Timing circuit. $R_t=50\Omega$, $R_b=200k\Omega$, $C_t=10nF$

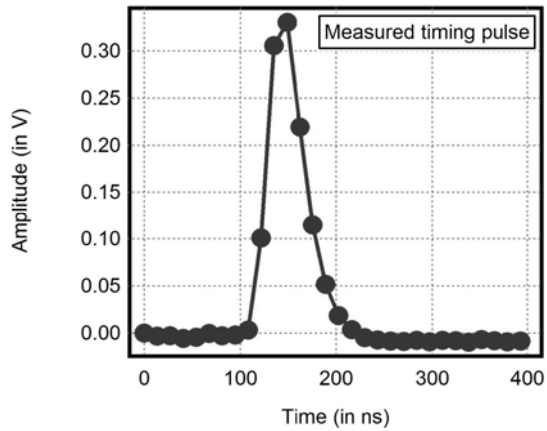

Fig. 4: Measured time signal (R2486). This signal was extracted by AC coupling the PSPMT dynode 12.

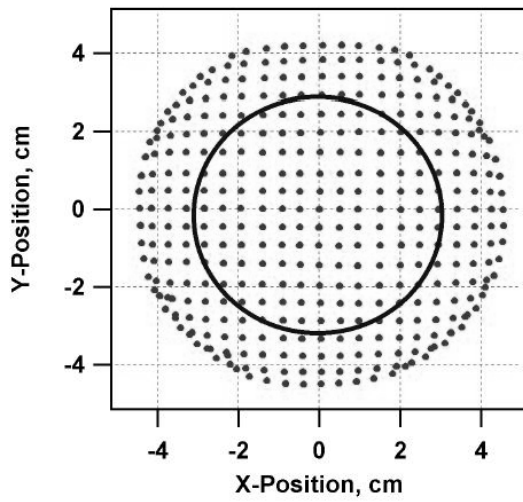

Fig. 5: R3292 Mapping function. Circle represents the active area (high linearity).

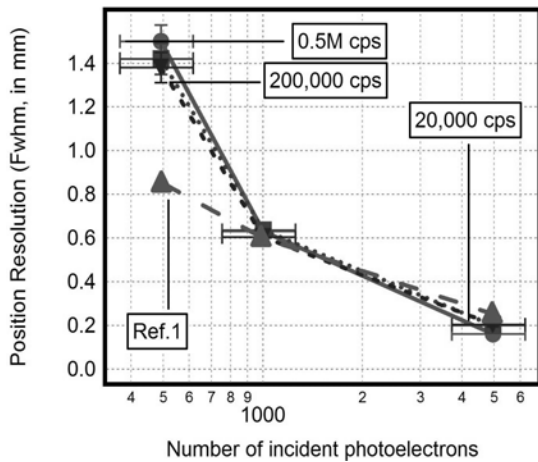

Fig. 6: Position resolution with number of incident photoelectrons and event rate (R2486). Ref.1 refers to the position resolution reported from the device datasheet.

Detector #1	Detector #2	Time resolution (fwhm)
3" CsI(Na), LF PMT	1" Plastic (EJ-212), PSPMT	5.8ns
1" NaI(Tl), LF PMT	1" Plastic (EJ-212), PSPMT	3.3ns
1" NaI(Tl), LF PMT	Plastic, LF PMT (R6095)	2.7ns

Table 1: Measured time resolution @ 511keV (R3292), 1,000 cps.

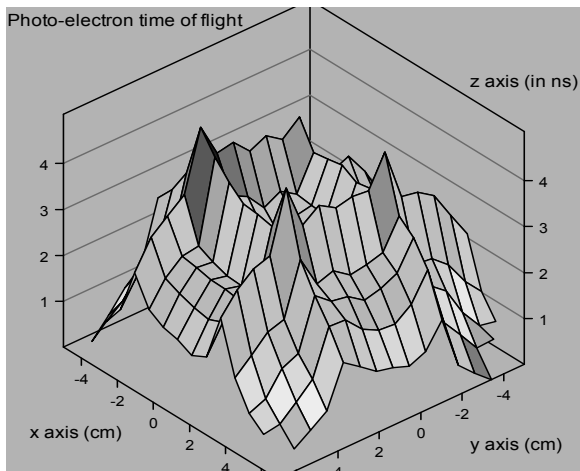

Fig. 7: Relative time of arrival with position (R3292).